



## PERIPHERAL PUMPS

### KF SERIES

#### INSTALLATION AND APPLICATIONS

These pumps are suitable for handling clean water not containing abrasive particles and fluids which are not chemically aggressive to the pump components. They are extremely reliable, light, economic and simple to use, finding many uses in domestic applications, in particular the automatic distribution of water from surge tanks, watering gardens and for boosting insufficient mains water pressure. These pumps should be installed in a covered area, protected against the weather.

#### OPERATING LIMITS

Suction lift up to 9 m  
 Fluid temperature up to + 60°C  
 Maximum ambient temperature +40°C

#### STRUCTURAL CHARACTERISTICS

<b>PUMP BODY</b>	Cast iron
<b>FORNT BODY COVER</b>	Cast iron
<b>PUMP BODY COVER</b>	Cast iron or bronze if necessary
<b>IMPELLER</b>	Brass , with radial peripheral blades, floating on the shaft.
<b>MECHANICAL SEAL</b>	Ceramic and graphite

#### MOTOR:

The pumps are coupled directly to an asynchronous, high efficiency SILVER ELEPHANT induction motor of suitable size, which is quiet running, close and extremely ventilated, with 1m b3 structural shape, suitable for continuous duty. Insulation class for b.

**The thermal cutout relay (motor protector) is incorporated in single phase motors.**

Three phase motors require an adequate external motor protector, with connections according to current standards.

**INSULATION** Class B

**PROTECTION** IP44

**CONSTRUCTION AND SAFETY STANDARDS** in compliance with IEC.

#### PERFORMANCE

The wide range of pumps in the KF series satisfies the most various operating requirements with features such as: high heads with respect to power requirements. Stable operating curves, with small variations in delivery rates with respect to large variations in the pressure demand. high tolerance of the presence of entrained air in the fluid to the pumped. Suction capacity up to 9 meters.

#### PERFORMANCE RANGE

Flow rate up to 60 l/min(3.6m<sup>3</sup>/h)  
 Dynamic head up to 60m

#### WARRANTY: 1 YEARS

(according to our general sales conditions).

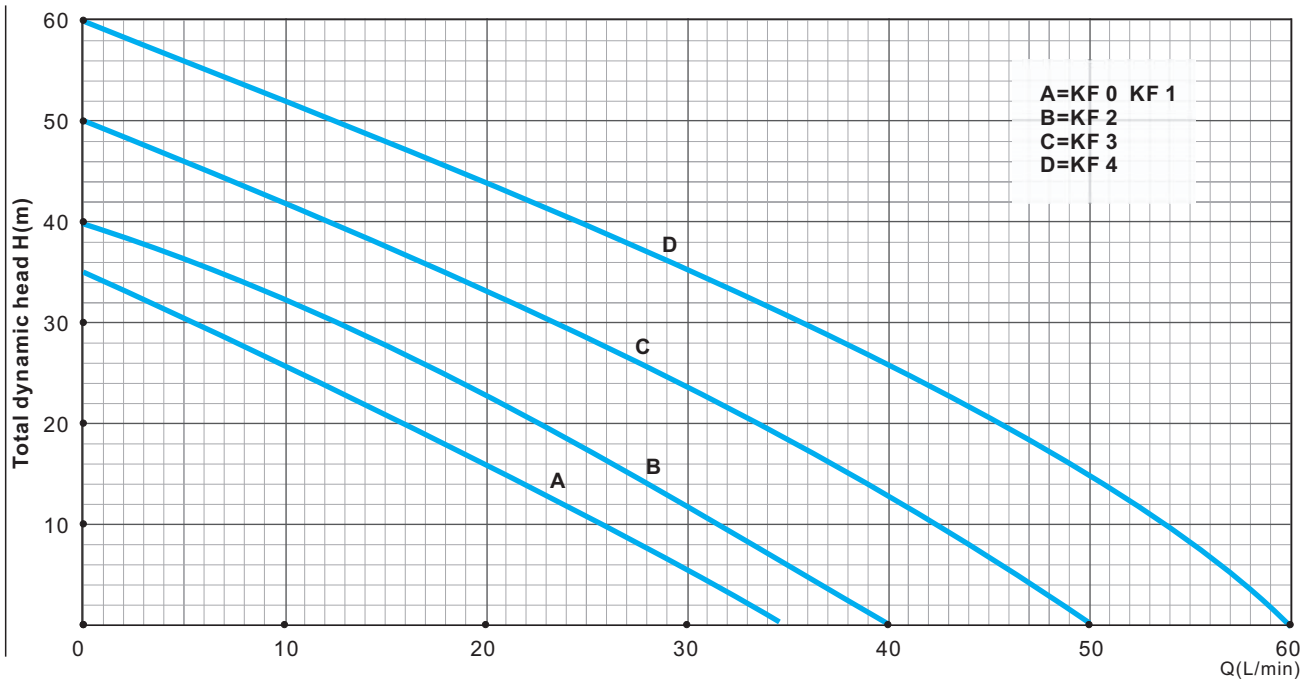

**TECHNICAL DATA**

Type	Power HP	Power kW	Ampere 1~220V	R.P.M	Q.Max (l/min)	H.Max (m)	S.Head (M)	Pipe Dia	L×W×H (mm)	N.W (Kg)
KF 0	0.5	0.37	1.6	2850	35	35	9	1"X1"	295X170X180	5.9
KF 1	0.5	0.37	1.6	2850	35	35	9	1"X1"	295X170X180	5.9
KF 2	0.75	0.55	3.6	2850	40	40	9	1"X1"	330X185X205	9.7
KF 3	1	0.75	4.8	2850	50	50	9	1"X1"	330X185X205	10.4
KF 4	1.5	1.1	6.2	2850	60	60	9	1½"X1½"	415X220X255	17.5

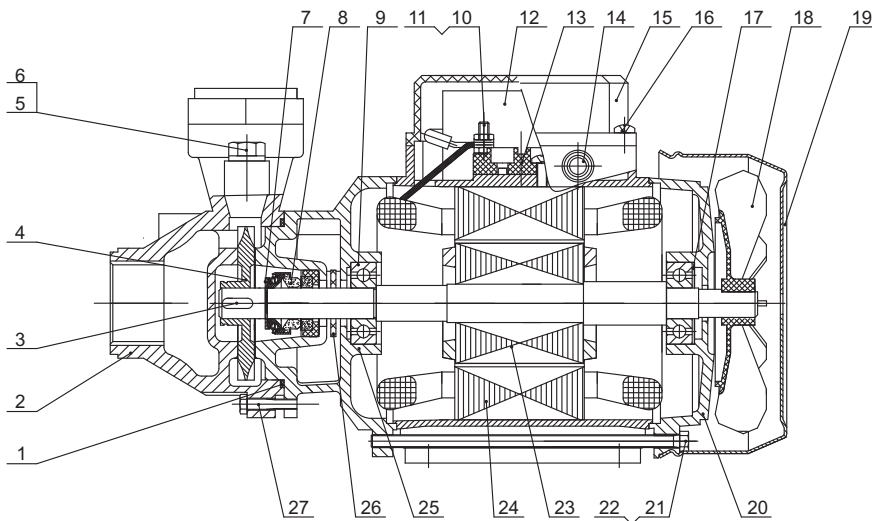

**MATERIAL DATA**

Item	Description.	Material	Item	Description.	Material	Item	Description.	Material	Item	Description.	Material	Item	Description.	Material
1	O ring	NBR	7	Snap ring		13	Terminal block		19	Fan cover		25	Front cover	
2	Pump body	HT-150	8	M. Seal		14	Fairlead		20	End cover	AL	26	Drops guard	NBR
3	Key	SS420	9	Bearings		15	Terminal Box	ABS	21	Screw		27	Screw	
4	Impeller	Brass H59	10	Screw		16	Screw		22	Washer				
5	Priming plug	Brass H59	11	Washer		17	Spring ring	65Mn	23	Rotor				
6	Ring	ABS	12	Capacitor		18	Fan	ABS	24	Stator				