



**JET-P SERIES**



## SELF-PRIMING JET PUMPS

### JET-P SERIES

#### INSTALLATION AND APPLICATIONS

These pumps are suitable for pumping clean water and fluids which are not chemically aggressive to pump components. They are extremely reliable, economical and simple to use, being particularly suitable for domestic applications such as the automatic distribution of water from small and medium-size tanks, watering gardens, etc. These pumps should be installed in a covered area, protected against the weather.

#### OPERATING LIMITS

Suction lift up to 9 m  
 Fluid temperature up to + 50°C  
 Maximum ambient temperature +40°C

#### PERFORMANCE

The wide range of pump in the JET-P series satisfied the most varied requirements with features such as:

- high heads with respect to power required.
- flat operating and power absorption curves, giving moderate curve variations with respect to large variations in delivery demand.
- high tolerance of the presence of entrained air in the fluid to be pumped.
- suction capacity up to 9 meters

#### PERFORMANCE RANGE

Flow rate up to 60 l/min (3.6m<sup>3</sup>/h)  
 Dynamic head up to 45m

#### WARRANTY: 1 YEARS

(according to our general sales conditions).

#### STRUCTURAL CHARACTERISTICS

<b>PUMP BODY</b>	Nylon
<b>HOLDING DISK</b>	Techno Polymer (approved For Drinking Water)
<b>FRONT COVER</b>	Aluminium
<b>EJECTOR UNIT</b>	Techno Polymer (approved For Drinking Water)
<b>IMPELLER</b>	Centrifugal Radial Flow In Brass Or Technopolymer (approved For Drinking Water) on Request.
<b>MECHANICAL SEAL</b>	Ceramic and graphite

#### MOTOR:

The Pumps Are Coupled Directly To An Asynchronous, High Efficient SILVER ELEPHANT Induction Motor Of Suitable Size, which Is Quiet Running, Closed And Extremely Ventilated, Suitable For Continuous Duty. Insulation Class B.

**The thermal cutout relay (motor protector) is incorporated in single phase motors.**

Three phase motors require an adequate external motor protector, with connections according to current standards.

**INSULATION** Class B

**PROTECTION** IP44

**CONSTRUCTION AND SAFETY STANDARDS** in compliance with IEC.

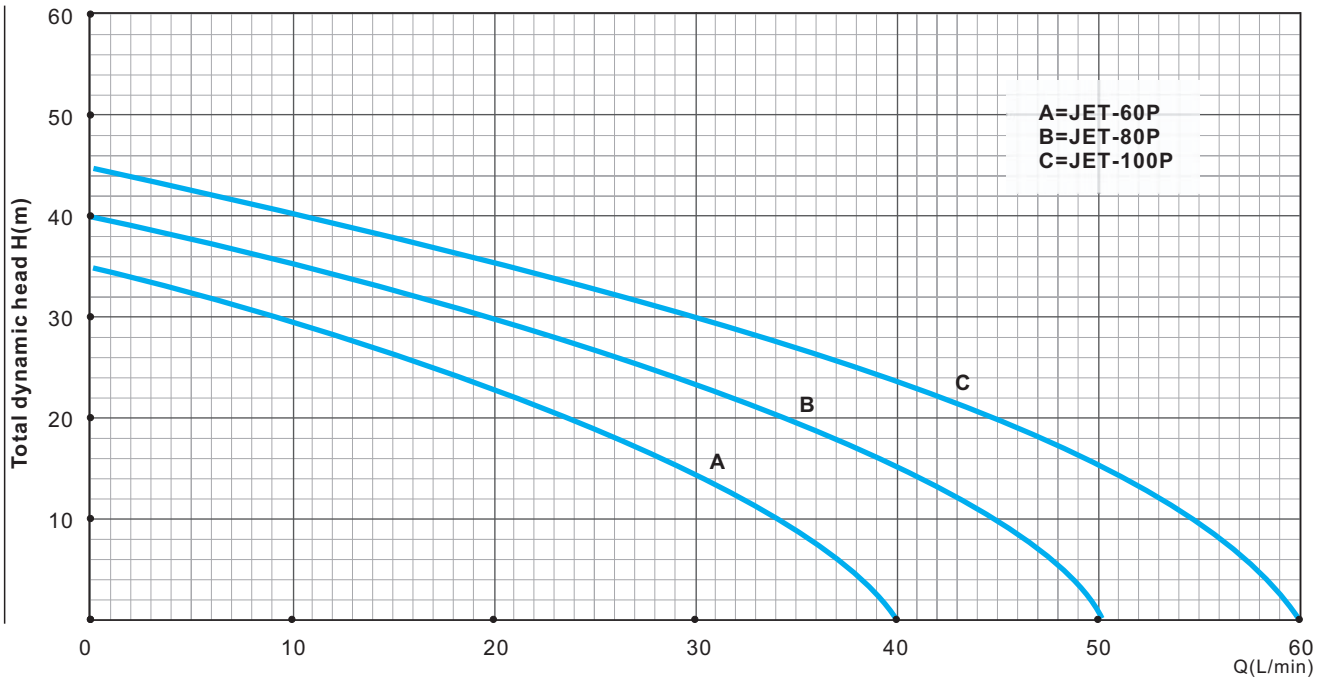

**TECHNICAL DATA**

Type	Power HP	Power kW	Ampere 1~220V	R.P.M	Q.Max (l/min)	H.Max (m)	S.Head (M)	Pipe Dia	L×W×H (mm)	N.W (Kg)
JET-60P	0.5	0.37	3	2850	40	35	9	1"X1"	410X220X220	7.6
JET-80P	0.75	0.55	3.6	2850	50	40	9	1"X1"	410X220X220	8.4
JET-100P	1	0.75	4.8	2850	60	45	9	1"X1"	410X220X220	9.4

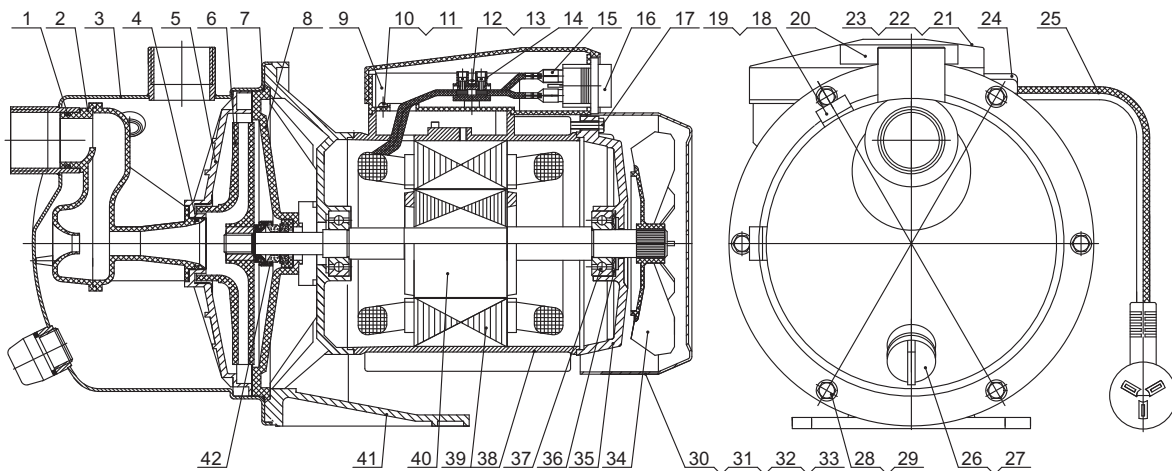

**MATERIAL DATA**

Item	Description.	Material	Item	Description.	Material	Item	Description.	Material	Item	Description.	Material	Item	Description.	Material
1	Ring	NBR	10	Screw		19	ring		28	Screw		37	Bearing	
2	Venturi	Noryl	11	Washer		20	Nameplate		29	Washer		38	Motor housing	AL
3	Pump body	Nylon	12	Screw		21	Screw		30	Fan cover		39	Stator	
4	Ring	NBR	13	Washer		22	Washer		31	Screw		40	Rotor	
5	Diffuser	Noryl	14	Terminal block		23	Washer		32	Washer		41	Front cover	AL
6	Impeller	Noryl	15	Connection		24	Cable ringer		33	Washer		42	M.seal	
7	O ring	NBR	16	Switch		25	Cable		34	Fan				
8	Pump Cover	Noryl	17	Screw		26	Drain plug		35	End cover				
9	Cpacitoy		18	Priming plug	ABS	27	Ring		36	Spring ring	65Mnl			