



**CMP/CM SERIES**



## CENTRIFUGAL PUMPS

### CMP/CM SERIES

#### INSTALLATION AND APPLICATIONS

These pumps are suitable for pumping clean water and fluids which are not chemically aggressive to the pump components. They are extremely reliable, simple to use, quiet and virtually maintenance-free, finding many uses in domestic and civil applications, and in particular the automatic distribution of water from small and medium-size surge tanks, transfer water, watering gardens, etc.

These pumps should be installed in a covered area, protected against the weather.

#### OPERATING LIMITS

Suction lift up to 7 m

Fluid temperature up to + 80°C

Maximum ambient temperature +40°C

#### PERFORMANCE

The range of pumps making up the CMP/CM series is particularly varied: however when developing the single units, care was taken to aim at standardizing the following features within the series:

Ample and stable characteristic curves

-Outputs having good absolute values and tendentially flat curves:

-Flat absorption curves at high delivery rates, preventing motor overloading even during prolonged use:

-Good suction capacities both at low and high delivery rates

#### PERFORMANCE RANGE

Flow rate up to 140 l/min (8.4 m<sup>3</sup>/h)

Dynamic head up to 44 m

#### WARRANTY: 1 YEARS

(according to our general sales conditions).

#### STRUCTURAL CHARACTERISTICS

<b>PUMP BODY</b>	Cast iron
<b>FRONT COVER</b>	Cast iron
<b>IMPELLER</b>	Brass, centrifugal radial flow type (technopolymer impeller on request)
<b>MECHANICAL SEAL</b>	Ceramic and graphite

#### MOTOR:

The pumps are coupled directly to an asynchronous, high efficiency SILVER ELEPHANT induction motor of suitable size, which is quiet running, close and extremely ventilated, suitable for continuous duty.

**The thermal cutout relay (motor protector) is incorporated in single phase motors.**

Three phase motors require an adequate external motor protector, with connections according to current standards.

**INSULATION** Class B

**PROTECTION** IP44

**CONSTRUCTION AND SAFETY STANDARDS** in compliance with IEC.

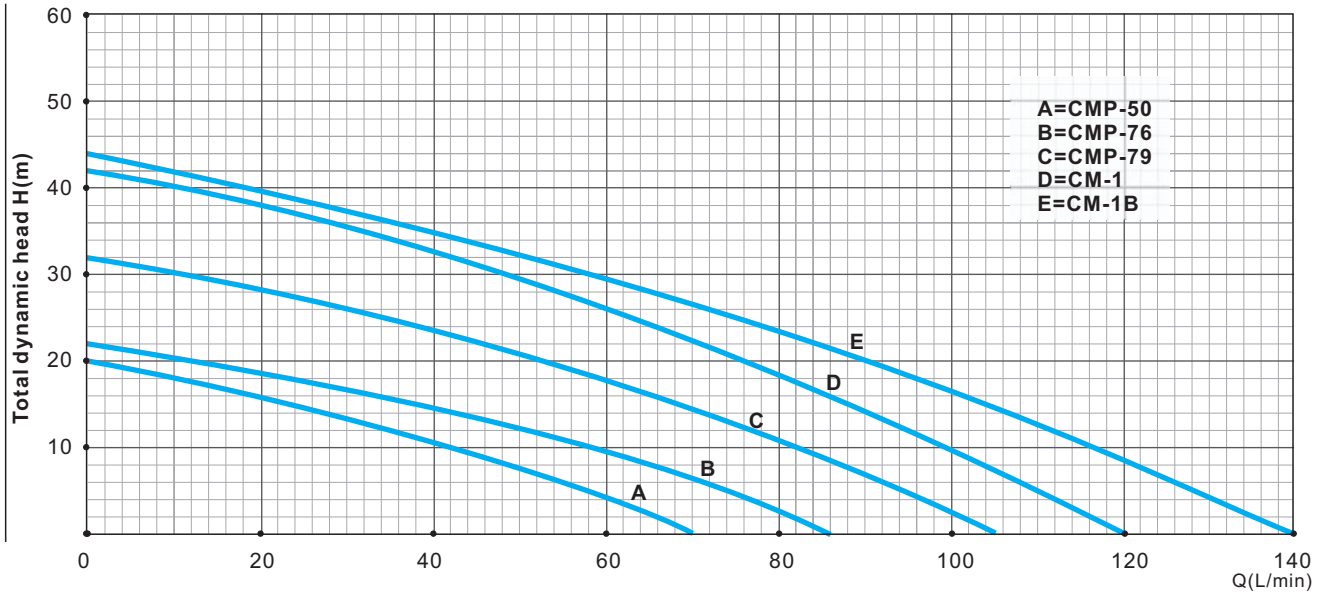

**TECHNICAL DATA**

Type	Power		Ampere 1~220V	R.P.M	Q.Max (l/min)	H.Max (m)	S.Head (M)	Pipe Dia	L×W×H (mm)	N.W (Kg)
	HP	kW								
CMP-50	0.5	0.37	2.7	2850	70	20	8	1"X1"	310X165X225	9.3
CMP-76	0.75	0.55	3.6	2850	85	22	8	1"X1"	330X165X225	10.5
CMP-79	1	0.75	5	2850	105	32	8	1"X1"	340X210X250	14.8
CM-1	1.5	1.1	7.5	2850	120	42	8	1"X1"	425X250X320	23
CM-1B	2	1.5	9.6	2850	140	44	8	1"X1"	425X250X320	26

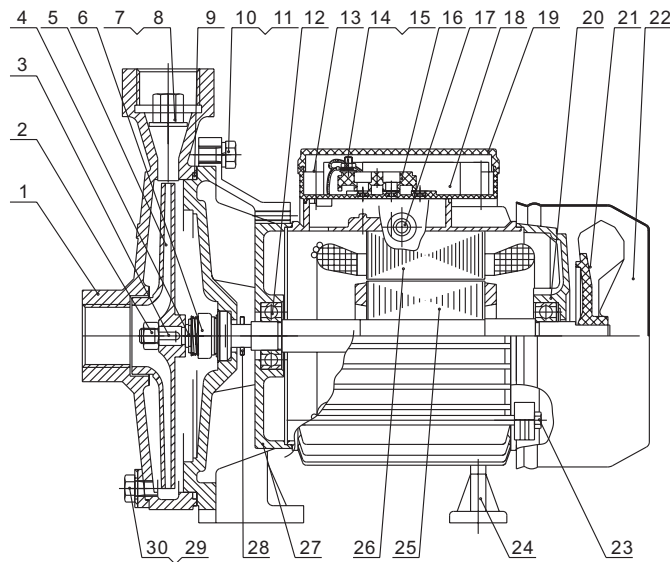

**MATERIAL DATA**

Item	Description.	Material	Item	Description.	Material	Item	Description.	Material	Item	Description.	Material	Item	Description.	Material
1	Pump Body	C.I.-HT200	7	Priming plug	Brass H59	13	Terminal box	ABS	19	Terminal Cover	ABS	25	Rotor	
2	Nut	SS420	8	Washer	NBR	14	Nut	H59	20	End Cover	AL-ZL102	26	Stator	
3	Key	SS420	9	O ring	NBR	15	Washer	T2	21	Fan	A3	27	Front Cover	C.I.HT200
4	Snap ring	SS420	10	Screw	A3	16	Terminal Block	ABS	22	Fan Cover	A3	28	Drops guard	NBR
5	Impeller	Brass H59	11	Washer	A3	17	Fairlead	NBR	23	Screw		29	Drain plug	H59
6	M. Seal	SS304&NBR...	12	Bearing		18	Capacitor	CBB60	24	Bottom foot		30	Washer	NBR